

Orcal Hook-on System RH215

For use with I-Bar suspension system

This Technical Data Sheet is offered as an aid to the specification of our products and provides information on the tiles manufactured at our European production facilities.

Orcal planks with Standard Perforation and Microperforation are available with factory applied black acoustic fleece, whilst Orcal tiles with Extra Microperforation are always supplied with factory applied black acoustic fleece.

Orcal tiles can also be made available to order with Premium B15 infill.

Please contact Armstrong Internal Technical Sales Group for further details.

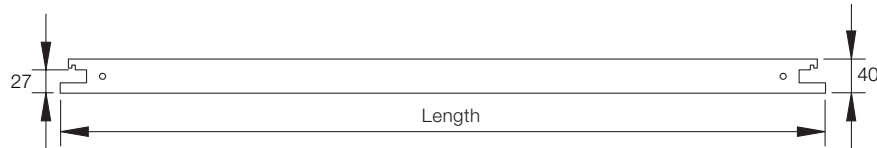

Width – Variable between 230mm to 500mm

Length – Up to 3000mm

*Note: Tiles supplied with 3mm foam gasket along 2 sides

(1 long & 1 short).

For product feasibilities outside these sizes or for other options, then please contact ITS.

Availability of products may vary according to country. Please contact your local Armstrong office for Product range information.

Material Products are manufactured from zinc coated mild steel. Steel gauge dependent on product size.

Finish Factory applied polyester powder coat, minimum thickness 55 microns.

Colour Standard: RAL 9010 & 'Global White'
Semi-Standard: RAL 9001, RAL 9002, RAL 9006, RAL 9007, RAL 9016
Other colours are available as special order items.

Gloss RAL 9010 : 20%
Global White : 20%
Semi-Standard : 30%
Measured in accordance with ISO 2813:2000, use 60° geometry.

Light Reflectance	Pattern	Light Reflectance	
		RAL 9010	Global White
	Plain (unperforated)	87%	77%
	Extra Microperforation with black fleece	85%	76%
	Microperforation with black fleece	71%	63%
	Standard Perforation with black fleece	75%	68%
Measured in accordance with ASTM 1477-98.			

Perforations	Standard Perforation	Microperforation	Extra Microperforation
	2.5mm dia.holes 16% open area	1.5mm dia. holes 22% open area	0.7mm dia. holes 1% open area

Other perforations are available as special order items. Please contact ITS for options and capabilities.

All measurements are in millimetres.

RH25 Layout & Grid components

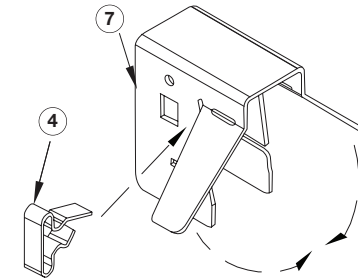
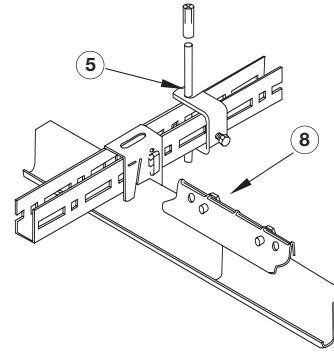
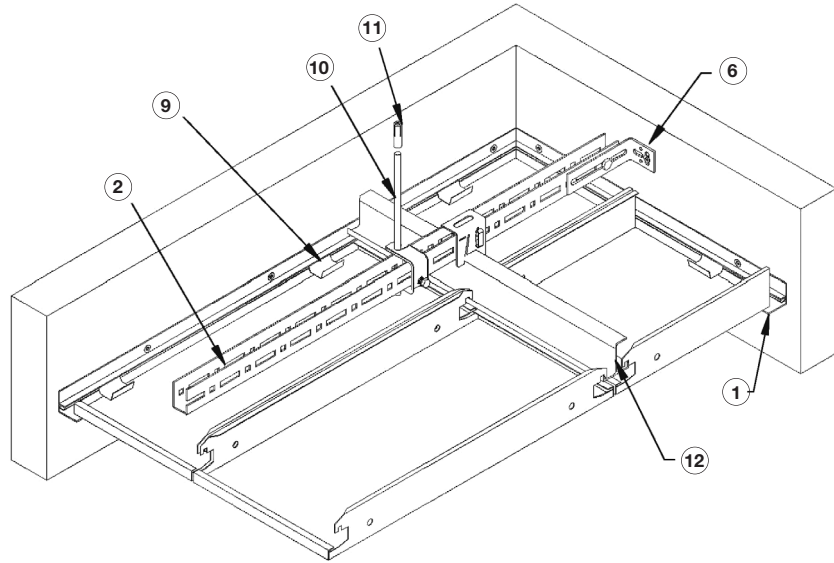
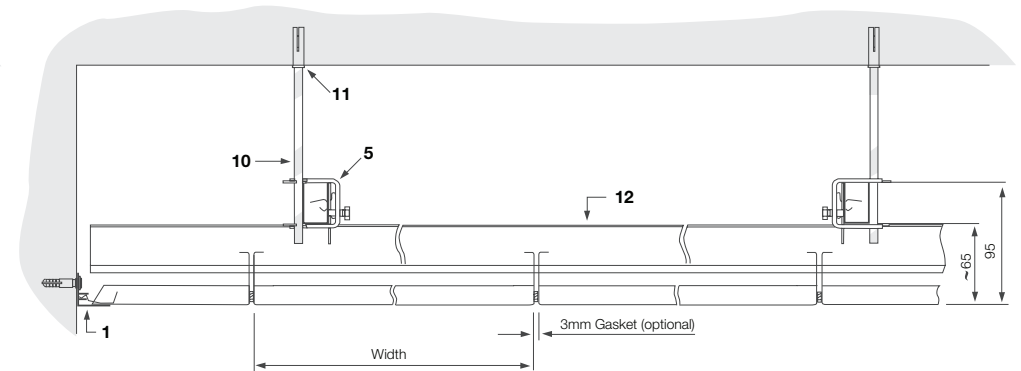
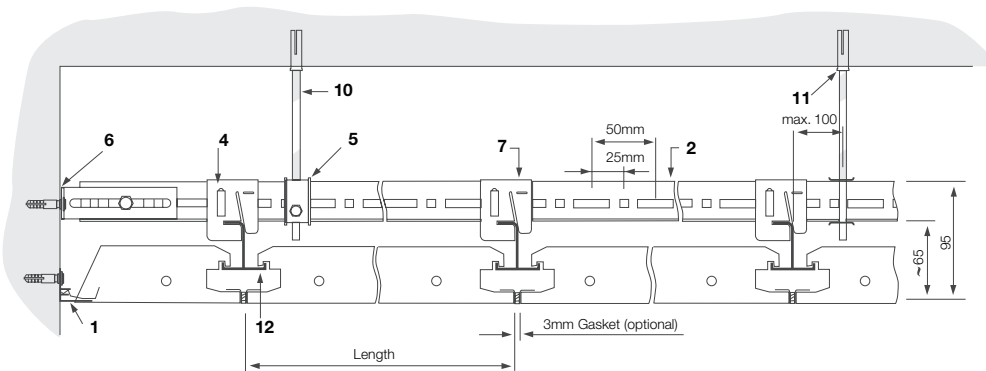

Fig.	Item No.	
1	BPM215013	Wall Angle
2	BPM300100	U-Profile
3	BPM300119	U-Profile Connector
4	BPM300120	Plug-In Clip
5	BPM300121	Clamping Bracket
6	BPM300140	Wall Anchor

Fig.	Item No.	
7	BPM300307	I / J-Bar Hanger
8	BPM300343	I / J-Bar Connector
9	BPM311081	Pressure Spring
10	BPM311099	Threaded Rod
11	BPM311111	Expansion Bolt
12	BPM311400	I-Bar

RH25 Side & End detail



All measurements are in millimetres.

Perimeter Solutions

Full tile:

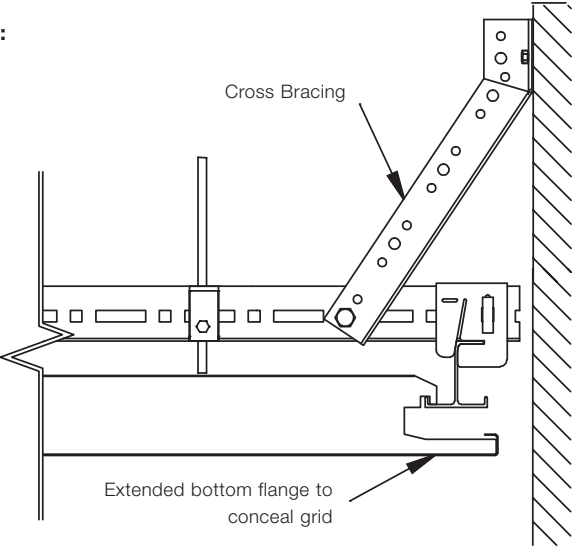

Cut tile:

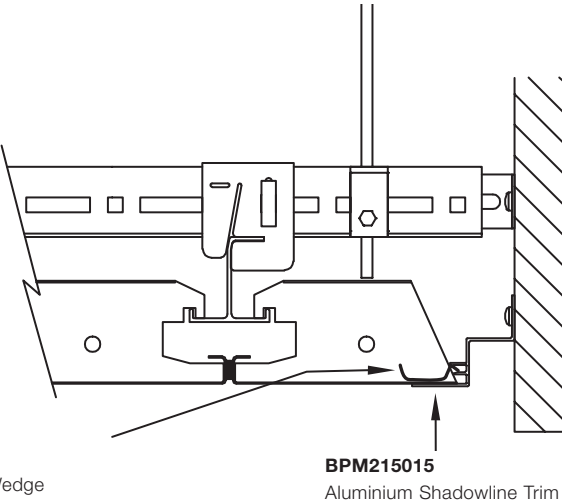
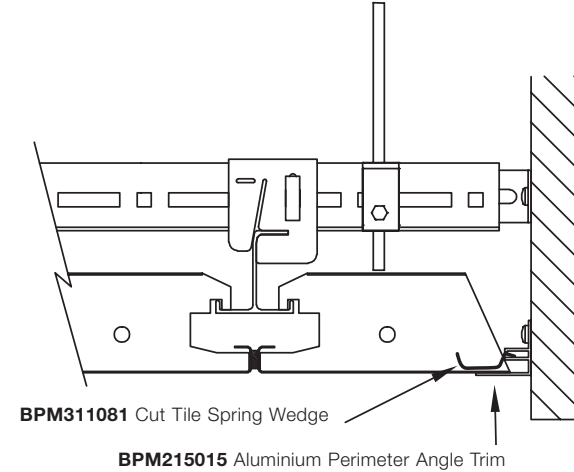
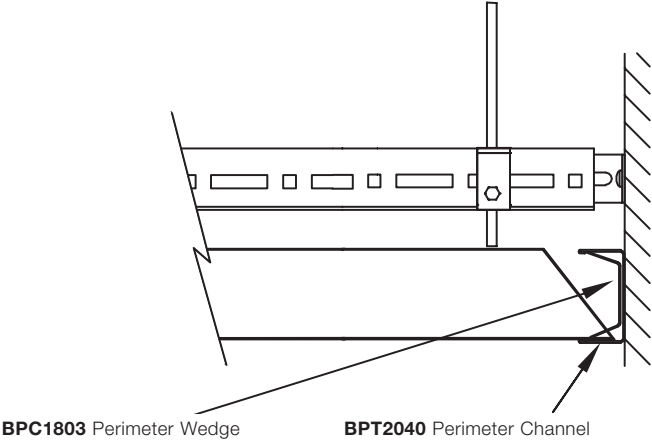

Cut the wedges **BPM311081** and **BPC1803**, 1 piece per 300mm of perimeter trim is recommended

Acoustic Performance**Sound Absorption (α_w)**

	Acoustic fleece	Premium B15 infill
Standard Perforation	0.70 (L)	0.60 (H)
Microperforation	0.75 (L)	0.60 (H)
Extra Microperforation	0.55 (L)	0.65 (L)

No acoustic infill (α_w)

Plain 0.10(L)

Room-to-room sound attenuation (Dncw)

	Acoustic fleece	Premium B15 infill
Standard Perforation	20 dB	41 dB
Microperforation	20 dB	41 dB
Extra Microperforation	30 dB	40 dB
Plain	–	47 dB

No acoustic infill (Dncw)

Plain 44 dB

A range of acoustic infills is available to achieve various acoustic performance levels. For further information please contact Armstrong Internal Technical Sales Group.

Tile Loading

Orcal tiles are capable of directly supporting limited additional loads from small service fittings. The maximum total uniformly distributed static load that can be applied to the rear of a 600x600mm tile should not exceed 3kg. The use of a patrix is recommended to distribute the load and to minimise face deflection of the tiles. Loads greater than 3kg should be independently suspended or supported from the primary grid. The maximum distributed static load that can be carried by the grid system should not exceed 10 kg/m².

(Applies to standard ladder formation with main runners and hangers at 1200mm centres.)

Services Integration

Orcal tiles can be supplied with factory produced cut outs and apertures for the integration of lighting fittings, air grilles, sprinklers, and other building services equipment.

Handling and Storage

Ceiling components should be stored under conditions of use in a dry interior location and should remain in cartons until installation. Cartons should be stacked and oriented as shown on the carton. Care must be exercised during handling and opening of cartons to avoid damage. The use of soft cotton gloves is recommended for tile installation.

Environmental

Our metal ceilings have an average of 25% recycling content. ISO 14001:2004 certified process.

United Kingdom
Republic of Ireland

Armstrong World Industries Ltd.
 Building Products Division
 Armstrong House
 38 Market Square
 Uxbridge UB8 1NG

0800 371849 (UK) **FREEPHONE**
1800 409002 (ROI)

Fax: +44 (0) 1895 274287

sales-support@armstrong.com

www.armstrong-ceilings.co.uk
www.armstrong-ceilings.ie
Other markets: www.armstrong-europe.com
Thermal Conductivity
 λ W/mK
 50.0 : Steel
 0.04 : Acoustic fleece
Humidity Exposure

Not greater than 70% RH @ 16°-23°C for long term exposure. Not greater than 95% RH for short term exposure during building site installation.

Fire Reaction**Plain without acoustic infill**

EEA Euroclass A1 (RAL 9010)

EEA Euroclass A2-s2, d0 (other colours)

No acoustic infillPerforated $\phi \leq 2.5$ mm

EEA Euroclass A1 (RAL 9010)

EEA Euroclass A2-s1, d0 (other colours)

With acoustic Fleece, ABBTF pad or B15 infillPerforated $\phi \leq 2.5$ mm (acoustic fleece)

EEA Euroclass A2-s2, d0

Perforated $\phi \leq 2.5$ mm (ABBTF pad)

EEA Euroclass A1

Perforated $\phi \leq 2.5$ mm (Premium B15 infill)

EEA Euroclass A2-s1, d0

Weight5 kg/m² – Steel tile**Field Cutting**

Orcal tiles can be cut using tin snips, electric sheet metal shears or band/jig saw. Care must be exercised to avoid damage to the painted surface, bending or distortion of the tiles.

Cleaning

Dust should be removed from the painted surface by wiping with a clean soft cloth. More stubborn marks should be removed with a mild household detergent in warm water. Excessive use of water should be avoided. The use of abrasive cleaners or scrubbing of the painted surface is not recommended.

Quality Standard

Armstrong is a certified ISO900:200 Quality Assumed Manufacturer. All tiles and products are manufactured to tolerances and quality standards in accordance with EN13964. Where differences exist between this and any expressed or implied architectural specifications or requirements than Armstrong's manufacturing standards will prevail unless stated otherwise.

Detailed NBS K40 specifications are available for these products, please contact Armstrong Internal Technical Sales Group for further details. All product specifications are subject to modifications without prior notice.